

The
Gold
Standard

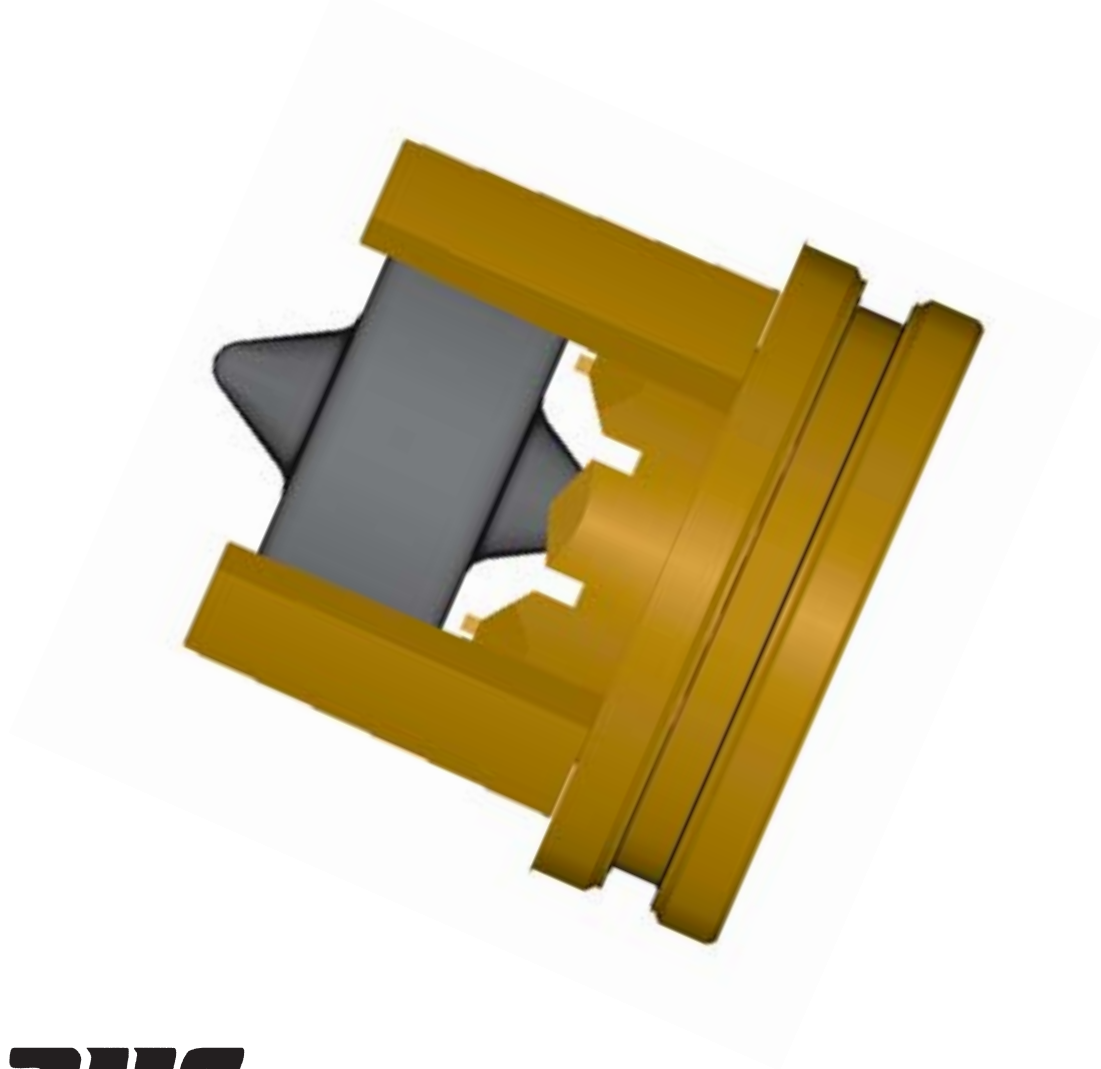

Hays
fluid controls

AUTOMATIC FLOW CONTROL VALVES

The Hays Mesurflo® Automatic Flow Control Valves have come under attack by two of our competitors. Hays finds this both flattering and disturbing. Flattering in that it wasn't long ago that they didn't know who we were; and disturbing because the reports are fraught with half-truths, untruths, inaccuracies and hyperbole.

The following report will dispel these myths and provide the facts one needs to make an informed decision.

There are three features that an Automatic Flow Control Valve must possess to accomplish the job in the HVAC industry.

- 1. Non-Clogging**
- 2. Quiet**
- 3. Accurate**

Hays and only Hays offers all three.

MESURFLO®

NON-CLOGGING

The live, flexing action of the Hays elastomeric diaphragm against the orifice seat permits passage of reasonably sized particles of sludge, Teflon tape, rust balls, thread chips and other debris.

MESURFLO®	BRAND X
 <p>The working parts are not in contact</p>	 <p>The working parts are close fitting, sliding surfaces that are susceptible to jamming.</p>

FIG. 1 0 PSID

MESURFLO®	BRAND X
 <p>The elastomeric diaphragm has moved onto the orifice seat. There are no close fitting parts to become fouled. Removing the differential pressure causes trapped debris to fall free.</p>	 <p>The spring loaded steel cartridge has recessed into the close fitting steel housing, causing trapped debris to become lodged between the sliding parts. Removing the differential pressure does not free the valve.</p>

FIG. 2 5 PSID

MESURFLO®	BRAND X
 <p>Back pressure forces the diaphragm away from the orifice seat allowing any debris to be back flushed away. Mesurflo® is the only balancing valve that provides unrestricted flow during back flush.</p>	 <p>Back pressure forces the piston to the full flow position causing any debris to become further lodged into the orifice slits.</p>

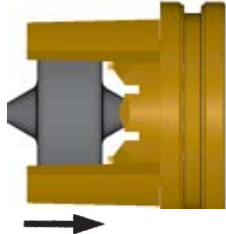
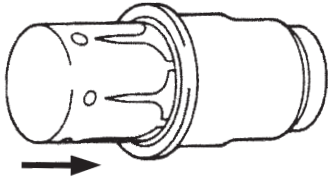
FIG. 3 BACKFLUSH

NON-CLOGGING TESTS

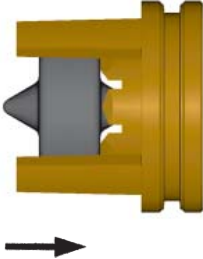
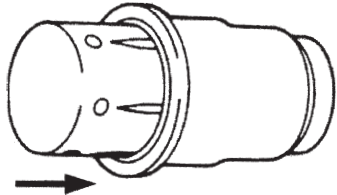
The patented Hays design has been the Naval Standard for 39 years in controlling raw seawater for heat transfer systems.

Tests were conducted with debris introduced into a closed hydronic system which contained a Hays Mesurflo® 4 GPM valve and a Brand X 4 GPM valve. The debris passed through the Hays Mesurflo®, but clogged Brand X valve.

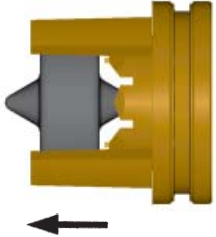
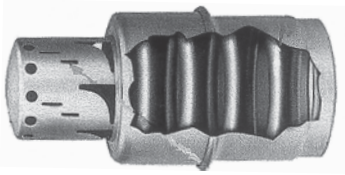
The clog resistant features of the Hays valve allow for the elimination of strainers from Water Source Heat Pumps and Fan Coil Piping Packages on closed loop systems.* The economic benefits do not stop at first cost, now there is no strainer to become clogged, no blow down valve, and no periodic maintenance.

*It is imperative that closed loop system installations follow the guidelines outlined in the ASHRAE handbook, "Cleaning and Flushing of Systems," 1976, Page 15.22. Prior to operation of any unit, the water circulation system must be free of all solids and debris. Therefore, installers must adhere to water source heat pump and fan coil manufacturers' instructions on system cleaning and flushing.

The box below is a quote from Brand X catalog:

PROBLEM: LOW WATER FLOW	
Possible Cause	Possible Solution
Balance Valve is Plugged	The Auto[matic] Flow valve may have debris. Remove cartridge, clean and replace

Absolute Solution: USE HAYS MESURFLO® VALVES

QUIET

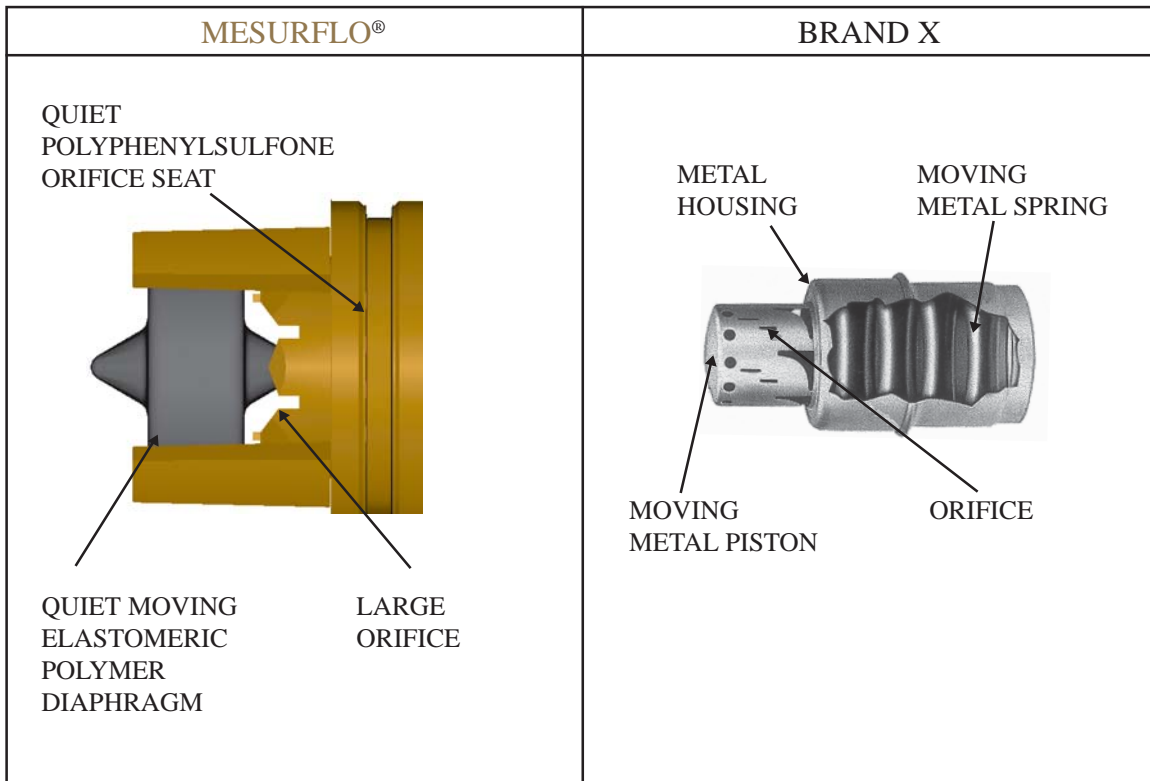

DESIGN

The Hays Mesurflo® Valve is quiet by design ----- quiet because its component parts are inherently quiet. The only moving part is an elastomeric polymer diaphragm and the orifice seat is made of polyphenylsulfone.

There are two very important reasons for using an elastomeric polymer diaphragm as the “HEART” of the Mesurflo®. First is its natural sound deadening ability and the second is hysteresis.

Hysteresis is defined : hys'ter•e'sis (-e'sis), *n. Physics.* a. A retardation of the effect, when the forces acting upon a body are changed.

Hysteresis prevents the Mesurflo® from becoming excited during times of extreme differential pressure change. It will not oscillate because of its self-dampening nature.

QUIET

The box below is a quote from Brand X catalog:

PROBLEM: NOISE OR VIBRATION	
Possible Cause	Possible Solution
Automatic Flow Valve is Clicking and Noisy.	Check the Delta P across the regulator and it may be necessary to replace the cartridge with a different spring range.

The Hays valve neither clicks nor is noisy and has only one control range. That control range is all you will ever need; 2 to 80 PSID.

We don't advertise the following fact because it is of little value in the HVAC industry, but the Mesurflo[®] actually controls flow within specification up to 150 PSID.

Absolute Solution: USE HAYS MESURFLO[®] VALVES

MILITARY

The Hays 2300 Series Mesurflo[®] valve has been the valve of choice for Navy submarines for the past 39 years because of its inherent quietness and clog resistant features. Beginning early in the 1990's the Navy set tougher acoustical standards for a new generation of submarines called the SEAWOLF. Hays, along with many other valve manufacturers were asked to develop a quieter balancing valve for the SEAWOLF, this was the genesis of our 2500 Series valve.

In 1995 the Navy asked the participating valve companies to submit their valves for testing. The standard against which all valves were measured was the Hays 2300 Mesurflo[®].

Results of these tests are classified, but the Navy did tell us that our 2500 valve was quieter than the original 2300 and that Hays would continue to be their valve of choice for new submarines. Hays continues to enjoy that position today.

QUIET

The Box Below is a Quote From Brand X Catalog:

HOW OTHER PORT SHAPES CAUSE VIBRATION

The choking effect (reduction in flow as ΔP increases) of a spring-loaded valve can cause severe vibration and oscillation in the fluid system. The larger the valve and higher the flow rate, the more violent the reciprocating motion of the valve will be. This instability can best be described as follows:

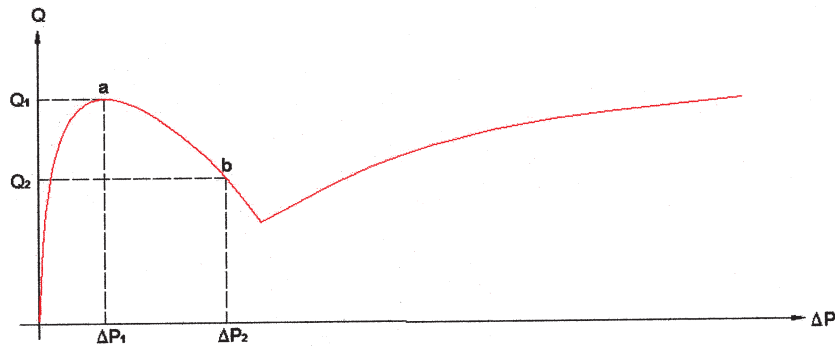

FIG. 7

As the differential pressure increases from ΔP_1 to ΔP_2 the valve piston depresses, resulting in a reduction of flow from Q_1 to Q_2 (a) to (b), FIG. 7. The reduced flow rate, Q_2 , however, results in a decrease in the system pressure drop (because of a decrease in pipe friction loss) which leads to an increase of flow rate and causes the valve to snap back from point (b) to (a). At point (a) on the curve, the system pressure drop ΔP_2 across the valve exceeds its new value ΔP_1 , thus causing the valve to snap to point (b). This oscillation back and forth from (a) to (b) and back to (a) will result in tremendous surges leading to high noise and vibration that can ultimately cause equipment damage and pipe rupture.

ACOUSTICAL TESTS

Acoustical tests were conducted at Hays using a half inch copper manifold with five parallel branches, each branch containing a Brand X Automatic Flow Control valve. Water pressure was introduced. When the differential pressure across the valve varied (within Brand X stated range) the valves began to oscillate uncontrollably, creating considerable vibration and noise, causing the flow rate to become erratic. The Brand X valves were removed and replaced with Mesurflo[®] valves. Using identical test protocol the Hays valves produced no oscillation, vibration or noise and the flow rate remained constant.

QUIET

The Box Below is a Quote From Brand X Catalog:

And while we're on the subject of oscillation, let's discuss the two other reasons why a FCV equipped system might oscillate. If a valve continuously operates at a transition point between the fixed orifice and variable orifice condition, it can cause "feedback" which is amplified by other valves in the system until oscillation occurs. Throttling the pump or installing a FCV with a higher control range will eliminate the condition.

The Hays Mesurflo® will not oscillate.

The Hays Mesurflo® has no transition point.

The Hays Mesurflo® is never a fixed orifice.

The Hays Mesurflo® will not cause feedback.

The Hays Mesurflo® only has one range, 2 - 80 PSID.

Absolute Solution: USE HAYS MESURFLO® VALVES

ACCURATE

What does accurate mean?

Is it the stable, predictable delivery of thermal energy in a hydronic system?

Or is it specmanship in advertising?

See graph below for answer.

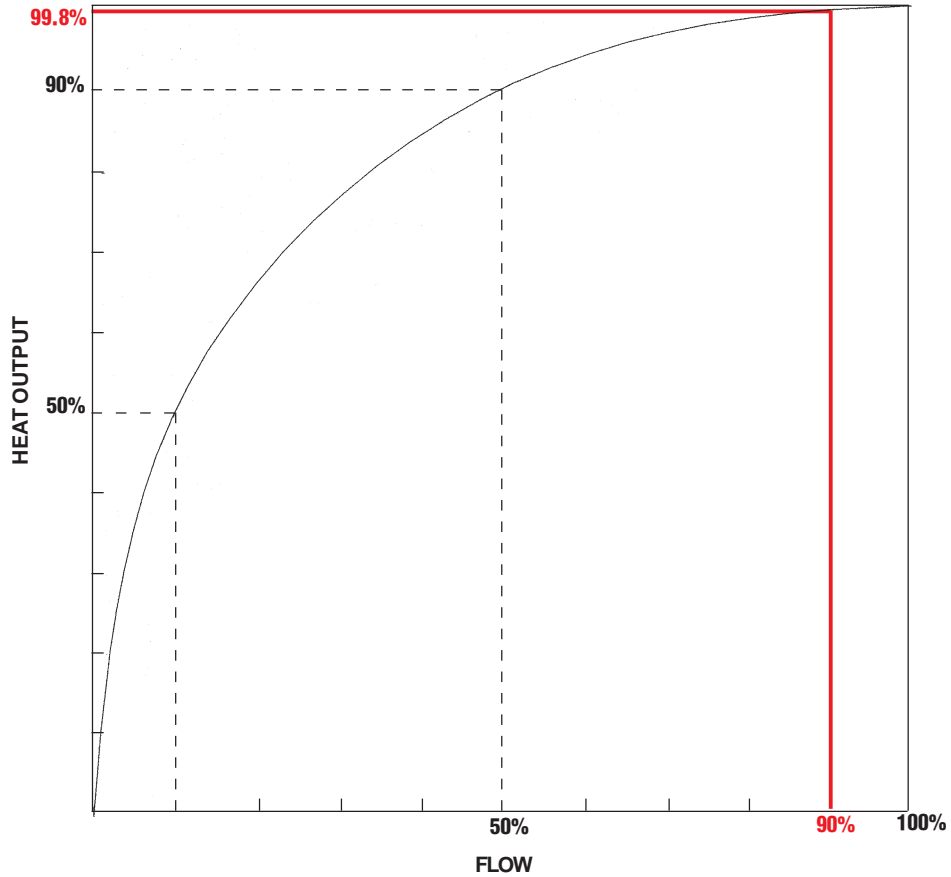

FIG. 17 1996 ASHRAE HANDBOOK; HVAC SYSTEMS AND EQUIPMENT

FLOW = HEAT TRANSFER

10% = 50.0%

50% = 90.0%

90% = 99.8%

The Hays Mesurflo® accuracy is $\pm 10\%$, that equates to 99.8% heat transfer.

ACCURATE

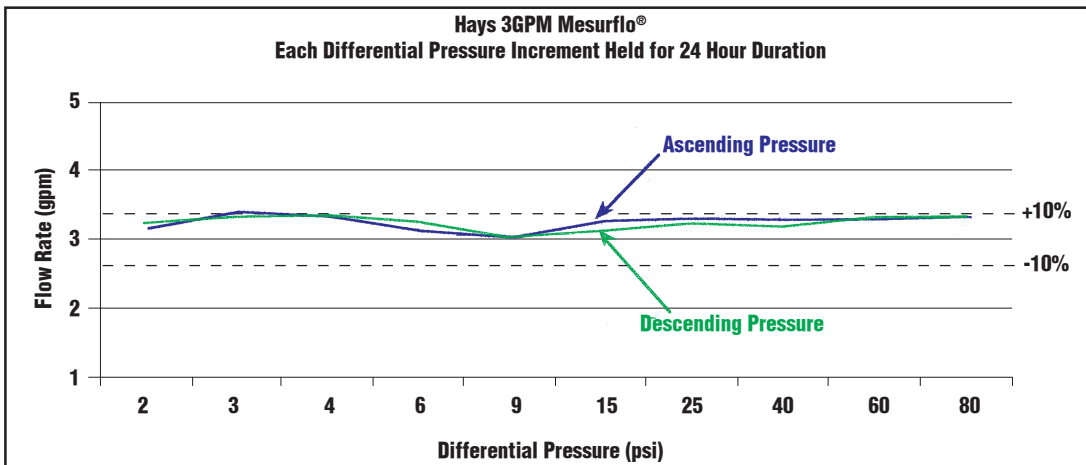
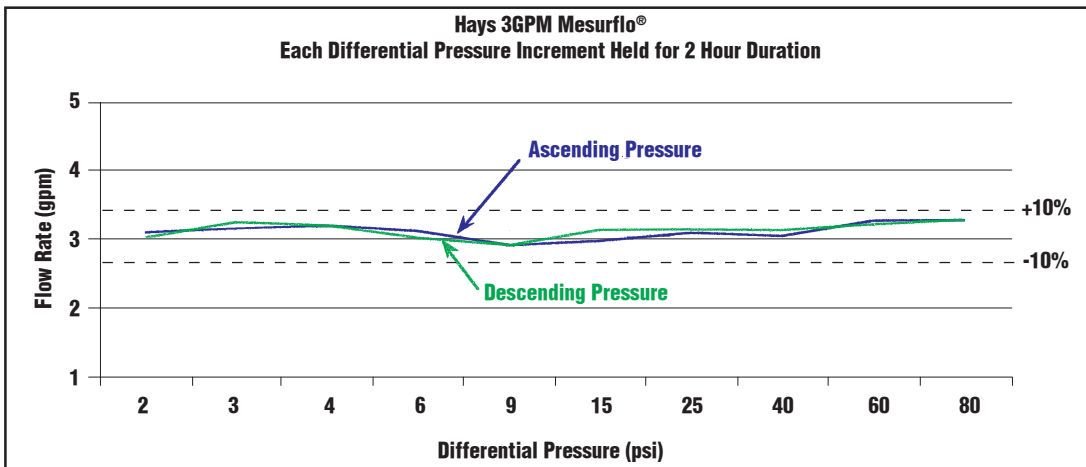
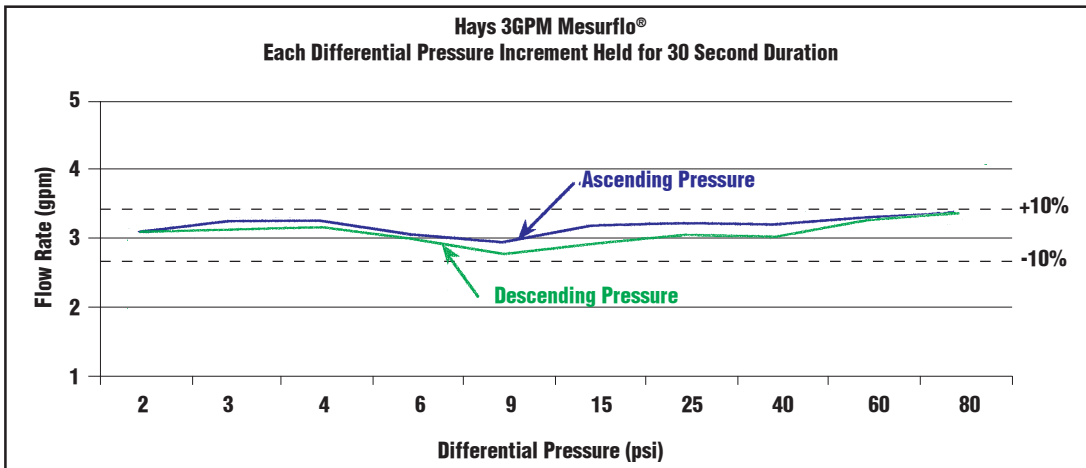

The graphs above depict the Mesurflo's® accuracy at three different time durations. Graph 1 is 30 seconds between differential pressure changes, Graph 2 is 2 hours between differential pressure changes and Graph 3 is 24 hours between differential pressure changes.

ACCURATE

TEMPERATURE COMPENSATION

The Mesurflo's® polymer diaphragm compensates for changes in fluid temperature.

CHILLED FLUIDS	HOT FLUIDS
The viscosity of fluids increases, causing less volumetric flow. See Graph A.	The viscosity of fluids decreases, causing more volumetric flow. See Graph A.
The specific gravity of fluids increase causing less volumetric flow. See Graph B.	The specific gravity of fluids decrease causing more volumetric flow. See Graph B.
The Mesurflo® polymer diaphragm strengthens, increasing the orifice area, causing greater volumetric flow.	The Mesurflo® polymer diaphragm softens, decreasing the orifice area, causing less volumetric flow.

Results: The change in a fluid's properties, due to a change in temperature is offset by the change in the polymer diaphragm caused by the same temperature change; provides stable thermal system performance.

The addition of antifreeze to the fluid further increases the need for the offsetting characteristics of the Mesurflo®.

ACCURATE

GRAPH A

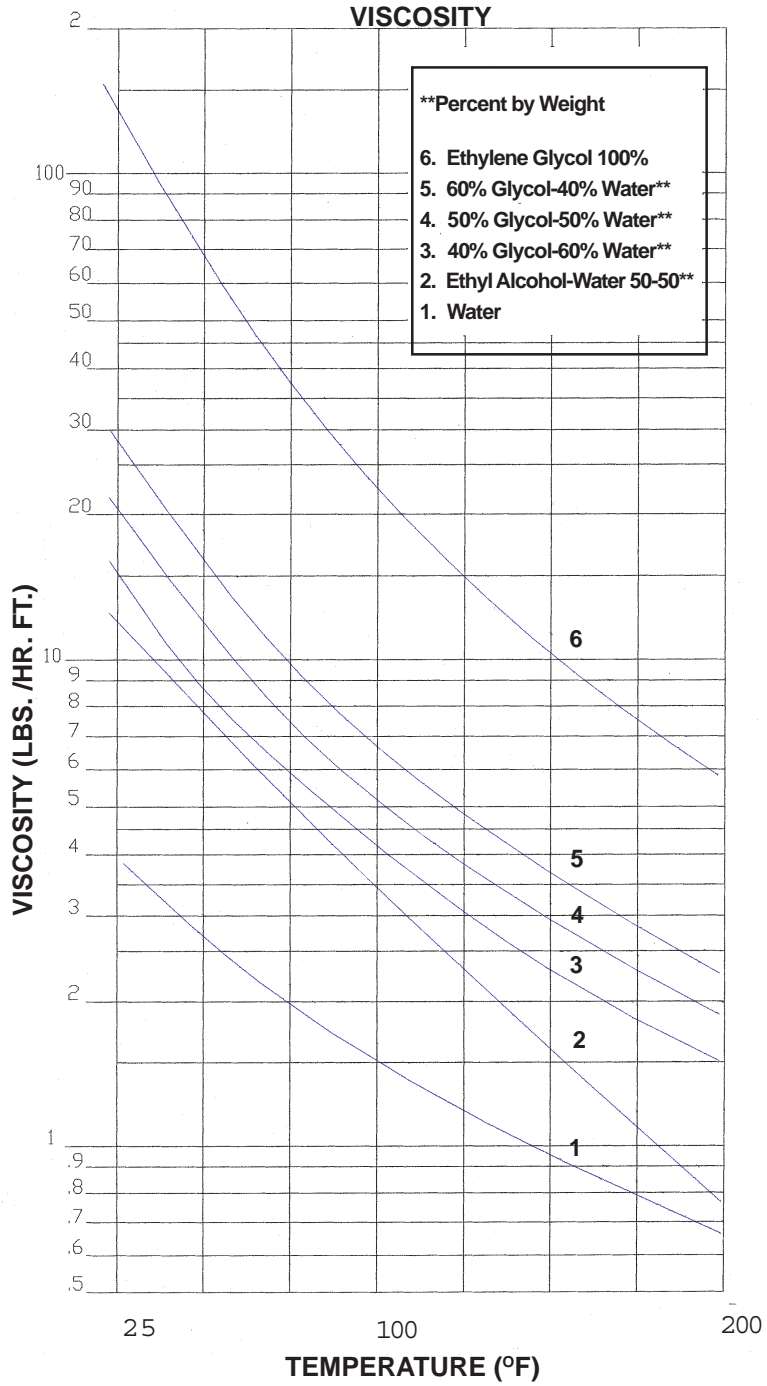

ACCURATE

GRAPH B

SPECIFIC GRAVITY FOR HEAT TRANSFER FLUIDS

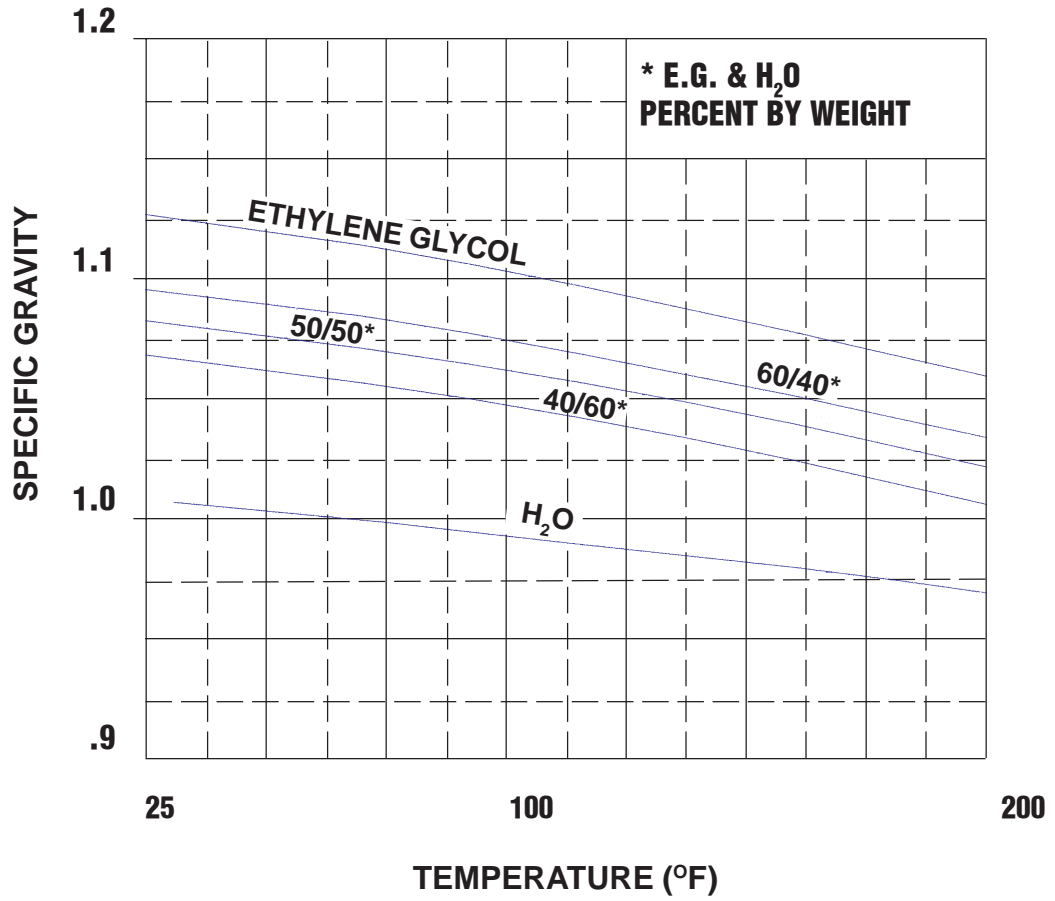

ACCURATE

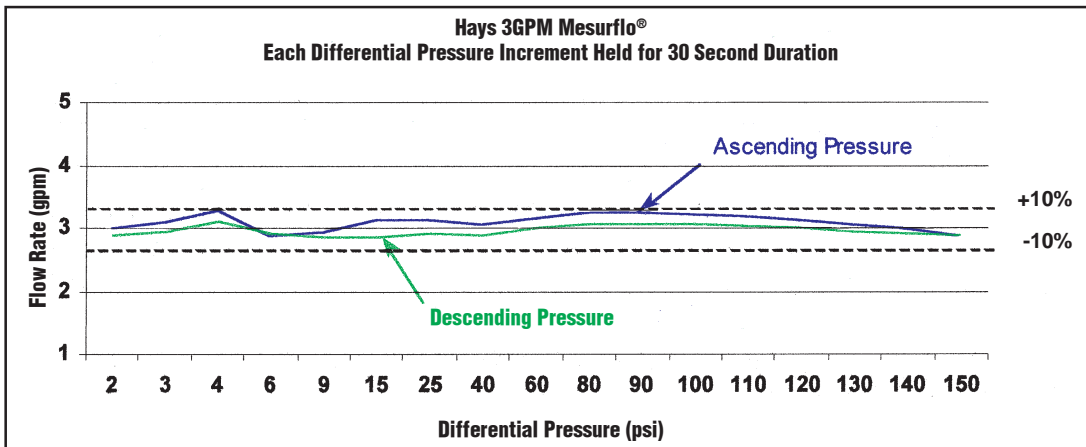
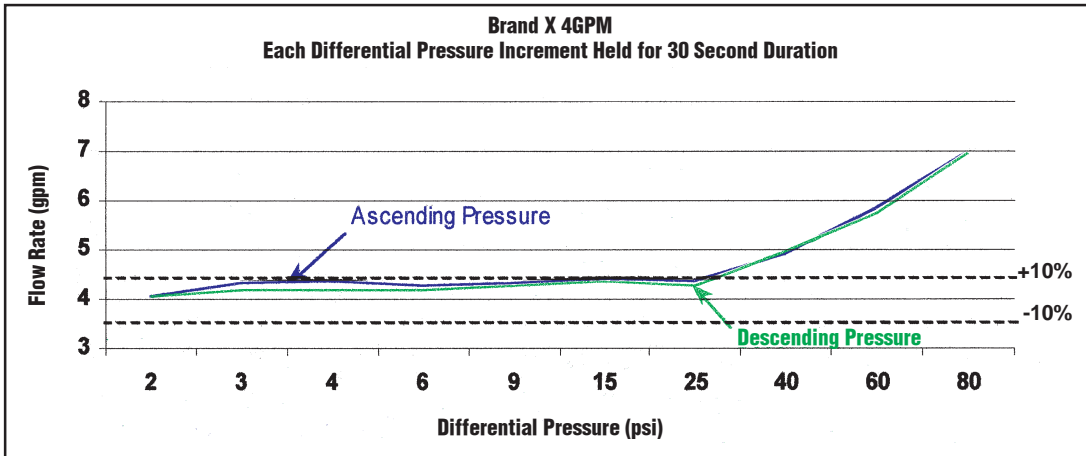

Forgive us for bragging, but we couldn't keep ourselves from showing you the same Hays valve functioning from 2 to 150 PSID. Amazing, but true.

Box below is a quote from Brand X catalog.

PROBLEM: HIGH WATER FLOW	
Possible Cause	Possible Solution
System Pressure is too High	Check the differential pressure across the Auto (matic) Flow valve. If larger than 32 psi, close the return side ball valve until the difference is less than 32 psi. The spring range on the cartridge could be changed to 5 - 60 which will also solve the problem.

Mesurflo® Valves function from 2 to 80 PSID; there is no need to worry about a 32 PSID limit; also, there is no spring to change.

Absolute Solution: USE HAYS MESURFLO® VALVES

SUMMARY

There is only one Automatic Balancing Valve that gives you all three:

1. **Non-Clogging**

- Interference Free Parts
- No Moving Metal Parts
- Unrestricted Back Flush
- No Springs - No Jamming

2. **Quiet**

- Elastomeric Polymer Diaphragm
- No Oscillation
- Polyphenylsulfone Orifice Seat
- No Vibration

3. **Accurate**

- 90% Flow = 99.8% Heat Transfer
- Temperature Compensation
- No Moving Parts That Wear
- 2-80 Differential Pressure Range

No more having to guess which Brand X valve might work (1-14?, 2-32?, 5-60?)
There is only one: 2-80 PSID!

Hays gives you the quickest delivery in the industry - and you don't pay a "Quick-Ship" premium!

All Hose Kits and Piping Packages are custom made, 100% tested and specifically tagged for the job!

Hays has a Lifetime Warranty!

The Navy has been a satisfied customer for nearly 40 years.

For more information or a Mesurflo® demonstration call us at 800-354-HAYS

Always Use Hays Mesurflo® Valves

The Gold Standard

Mesurflo[®] Family

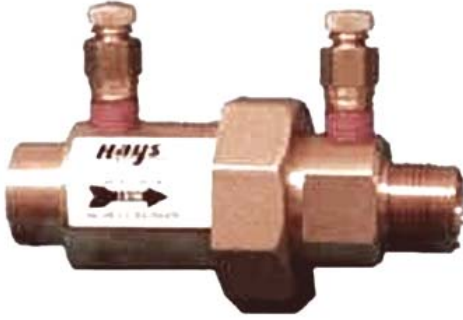

Mesurflo 2510

Flow Rates from .5 GPM to 10 GPM



Y-Ball Mesurflo 2514



Mesurflo 2513

Flow Rates from .5 GPM to 10 GPM



Y-Ball Mesurflo 2516



Mesurflo 2520

Flow Rates from .5 to 24 GPM



Y-Ball Mesurflo 2524

Hays
fluid controls

P.O. BOX 580
DALLAS, NC 28034-0580

800-354-4297

FAX (704) 922-9595

www.haysfluidcontrols.com